

BMG E3D V6 Direct-Drive for Ender 3 Assembly Manual

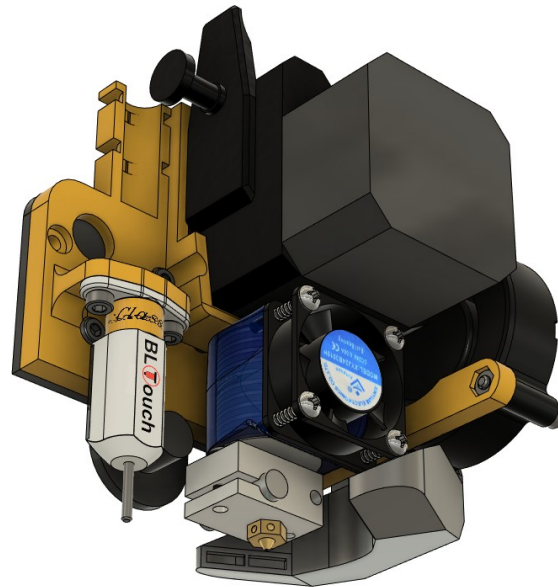

Step 1: Connect the E3D V6 hotend at the output of the BondTech BMG (PTFE tube length = 37 mm)



Step 2: Insert the NEMA 17 Stepper motor into the BondTech BMG

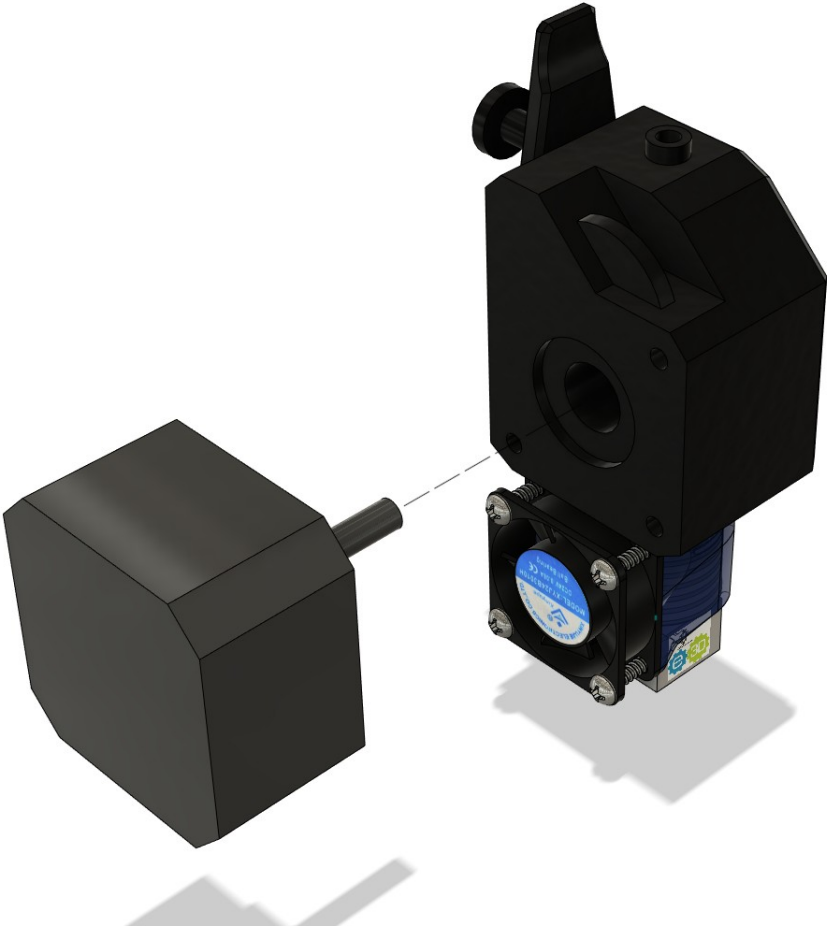

Step 3: Connect the BondTech E3D V6 assembly to the BMGV6 Plate

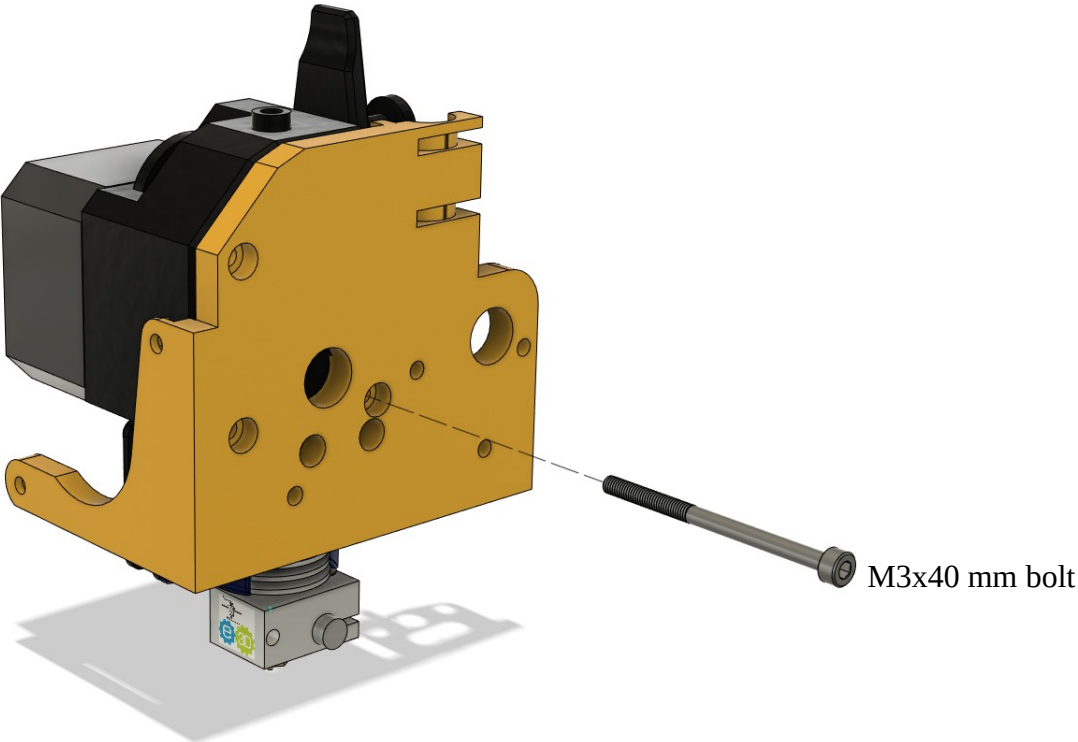

Step 4: Attach the assembly from Step 3 to the printer carriage (holes for Ender 3 Pro shown on picture)

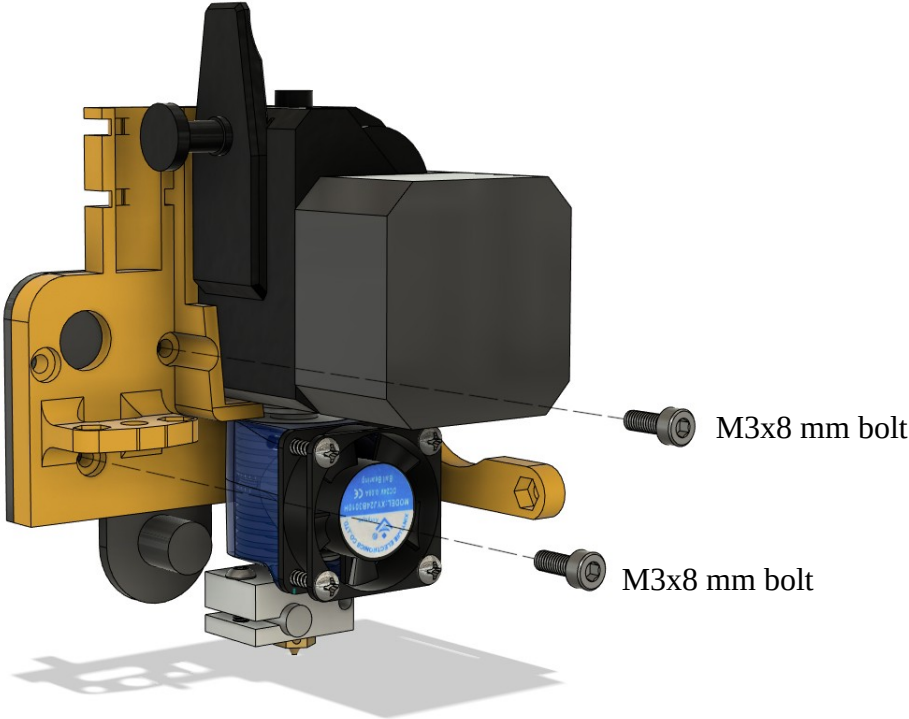

Step 5: Attach the BMG V6 back brace

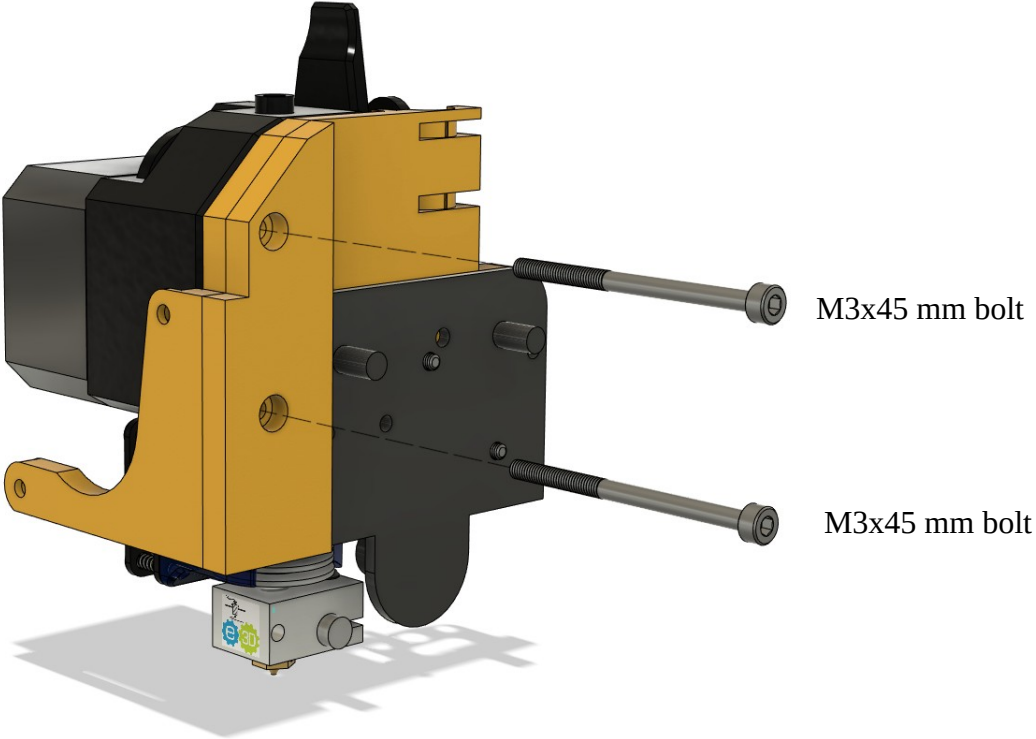

Step 6: Insert the 5015 blower fan into the fan duct

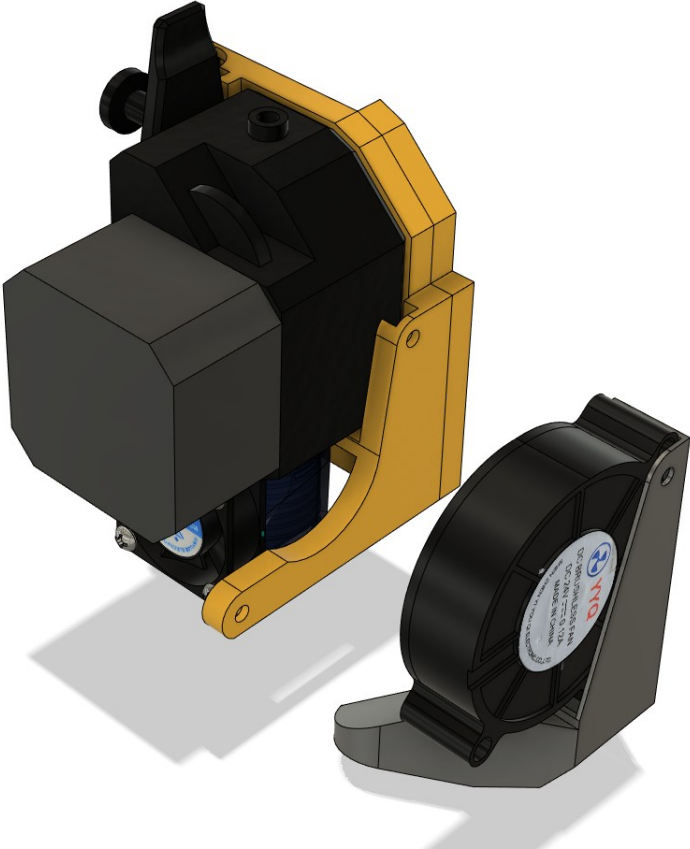

Step 7: Insert 2x M3 nuts to attach the fan duct assembly

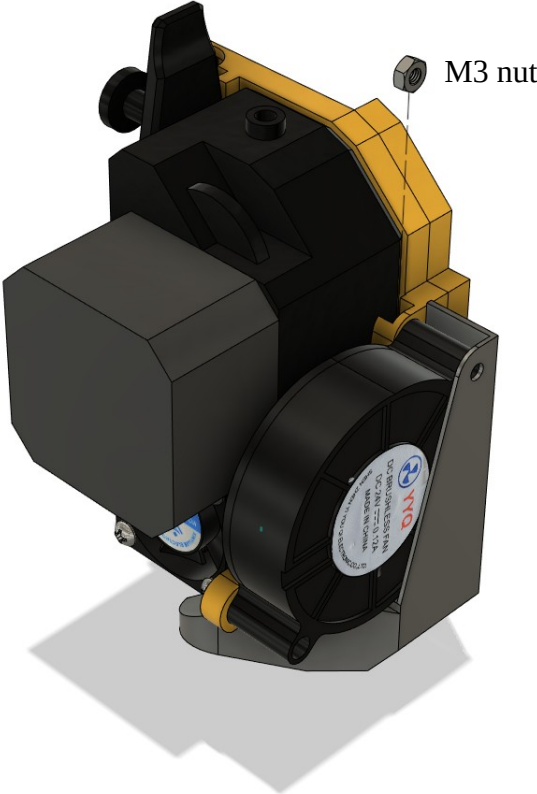

Step 7 Continued

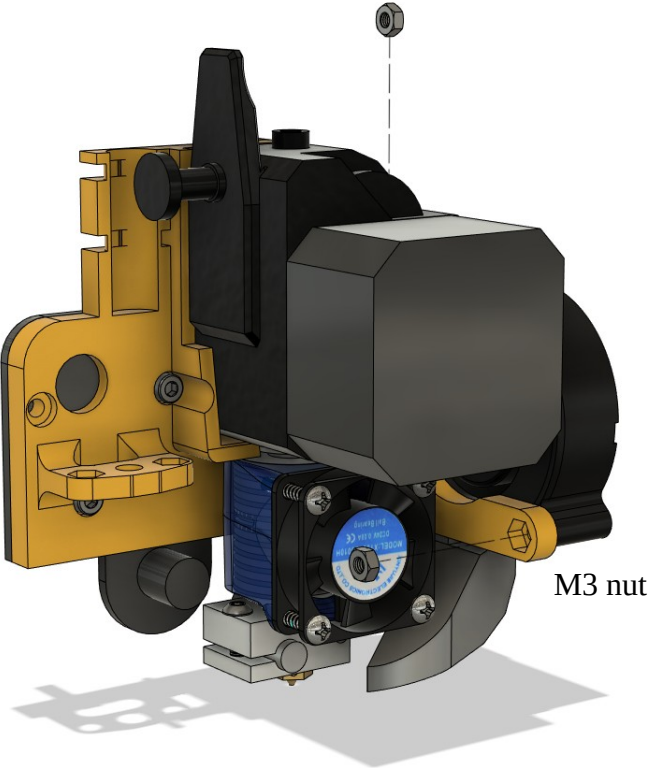

Step 8: Attach the fan duct assembly

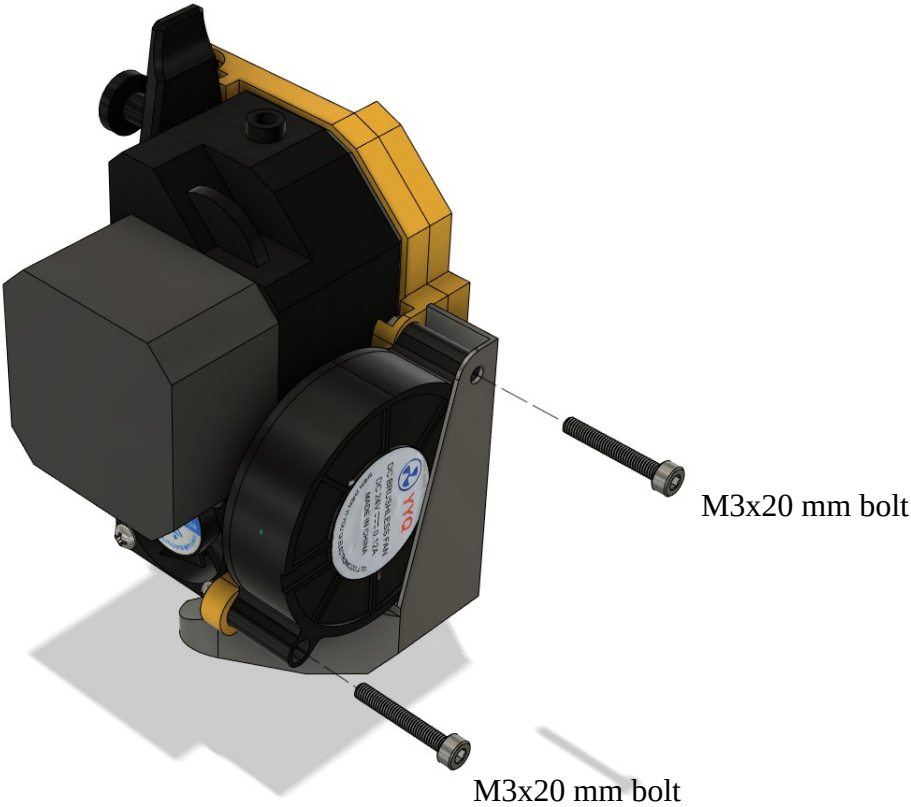

Step 9: Attach the BLTouch

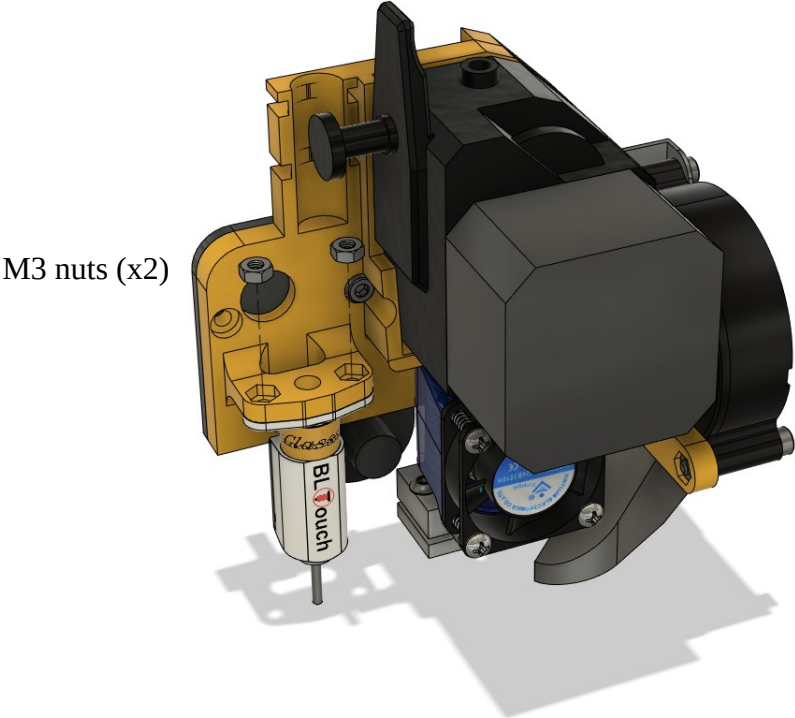

Step 9 Continued: Attach the BLTouch

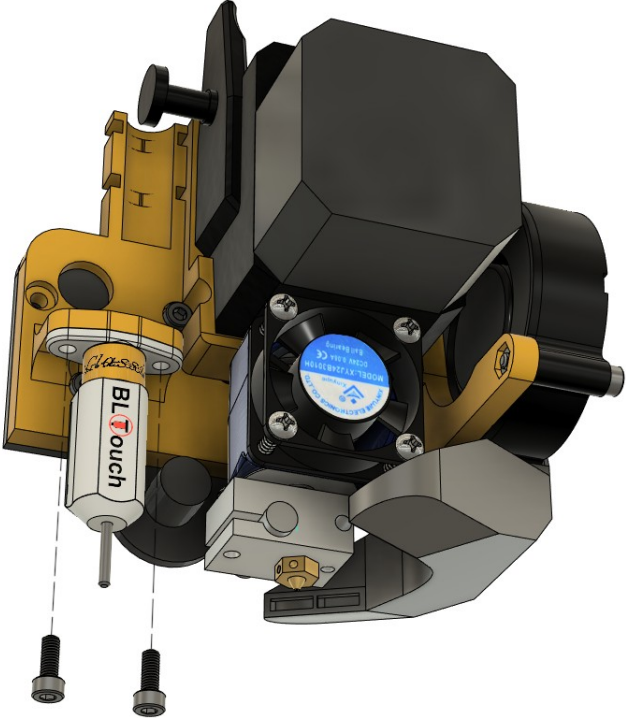

M3x8 mm bolts (x2)

Step 10: Attach cables to the base with 2 zip ties

